



**Chuck E. Cheese's Big Win Super Spin
OWNERS AND SERVICE MANUAL
INNOVATIVE CONCEPTS IN ENTERTAINMENT INC.**

10123 MAIN STREET, CLARENCE, NY 14031

SERVICE: 1-716-759-0360

FAX: 1-716-759-0884

E-MAIL: service@icegame.com

WEBSITE: www.icegame.com

TABLE OF CONTENTS

SAFETY & WARNINGS.....	PAGE 3
• BEFORE YOU BEGIN	
• INSTALLATION	
• WARNING	
GAME SETUP & FEATURES.....	PAGE 4-11
• MARQUEE ASSEMBLY	
• MARQUEE ELECTRICAL SETUP	
• INSERTING PAPER	
• HOW TO REMOVE REMAINING PAPER ROLL	
• ELIMINATING JAM IN THE PRESENTER	
• ELIMINATING THE PAPER JAM	
• RELEASING A LOCKED CUTTER	
• Hopper Option	
ELECTRICAL COMPONENTS.....	PAGE 12-13
PROGRAMMING OF BIG WIN SUPER SPIN.....	PAGE 14-19
TROUBLESHOOTING.....	PAGE 20-24
MAINTENANCE.....	PAGE 25
SCHEMATIC.....	See insert
PARTS LISTING.....	PAGE 30
WARRANTY INFORMATION.....	PAGE 31-32

SAFETY AND WARNINGS

BEFORE YOU BEGIN

WARNING: WHEN INSTALLING THIS GAME, A GROUNDED A.C. RECEPTACLE MUST BE USED. FAILURE TO DO SO COULD RESULT IN INJURY TO YOURSELF OR OTHERS. FAILURE TO USE A GROUNDED RECEPTACLE COULD ALSO CAUSE IMPROPER GAME OPERATION, OR DAMAGE TO THE ELECTRONICS.

DO NOT DEFEAT OR REMOVE THE GROUNDING PRONG ON THE POWER CORD FOR THE SAME REASON AS GIVEN ABOVE. USING AN IMPROPERLY GROUNDED GAME COULD VOID YOUR WARRANTY.

HAVE A QUALIFIED ELECTRICIAN CHECK YOUR A.C. RECEPTACLE TO BE SURE THE GROUND IS FUNCTIONING PROPERLY.

INSTALLATION

The game comes ready to play with just a few simple things to keep in mind.

1. Plug the game into the A.C. outlet and turn on power to the game. The switch for the game is located on a power module on the outside rear of the game.

THIS GAME IS DESIGNED TO DISSIPATE STATIC ELECTRICITY THROUGH THE GROUNDING PLANE OF THE GAME. IF THE A.C. GROUND DOES NOT WORK, THE GAME COULD DISCHARGE STATIC ELECTRICITY THROUGH THE GAME CIRCUITRY, WHICH COULD CAUSE DAMAGE.

2. Make sure the game is level after installation. It is necessary to make sure the game is level for safety concerns.
3. Check that the A.C. voltage rating on the back of the game matches the A.C. voltage of your location.

THE POWER SUPPLY IS NOT VOLTAGE ADJUSTABLE. TO OPERATE THE GAME AT VOLTAGES OTHER THAN THOSE IT WAS DESIGNED FOR. PLEASE CONTACT OUR SERVICE DEPARTMENT FOR VOLTAGE CONVERSION INFORMATION.

WARNING

DO NOT remove any of the components on the main board (e.g. compact flash and eproms) while the game is powered on. This may cause permanent damage to the parts and the main board. Removing any main board component part while powered on will void the warranty.

NOTE: THIS GAME IS INTENDED FOR INDOOR USE ONLY.
ON THE BACK PANEL OF THE GAME: WARNING: SHOCK HAZARD - DO NOT OPEN. REFER SERVICING TO SERVICE PERSONNEL.

MARQUEE ASSEMBLY

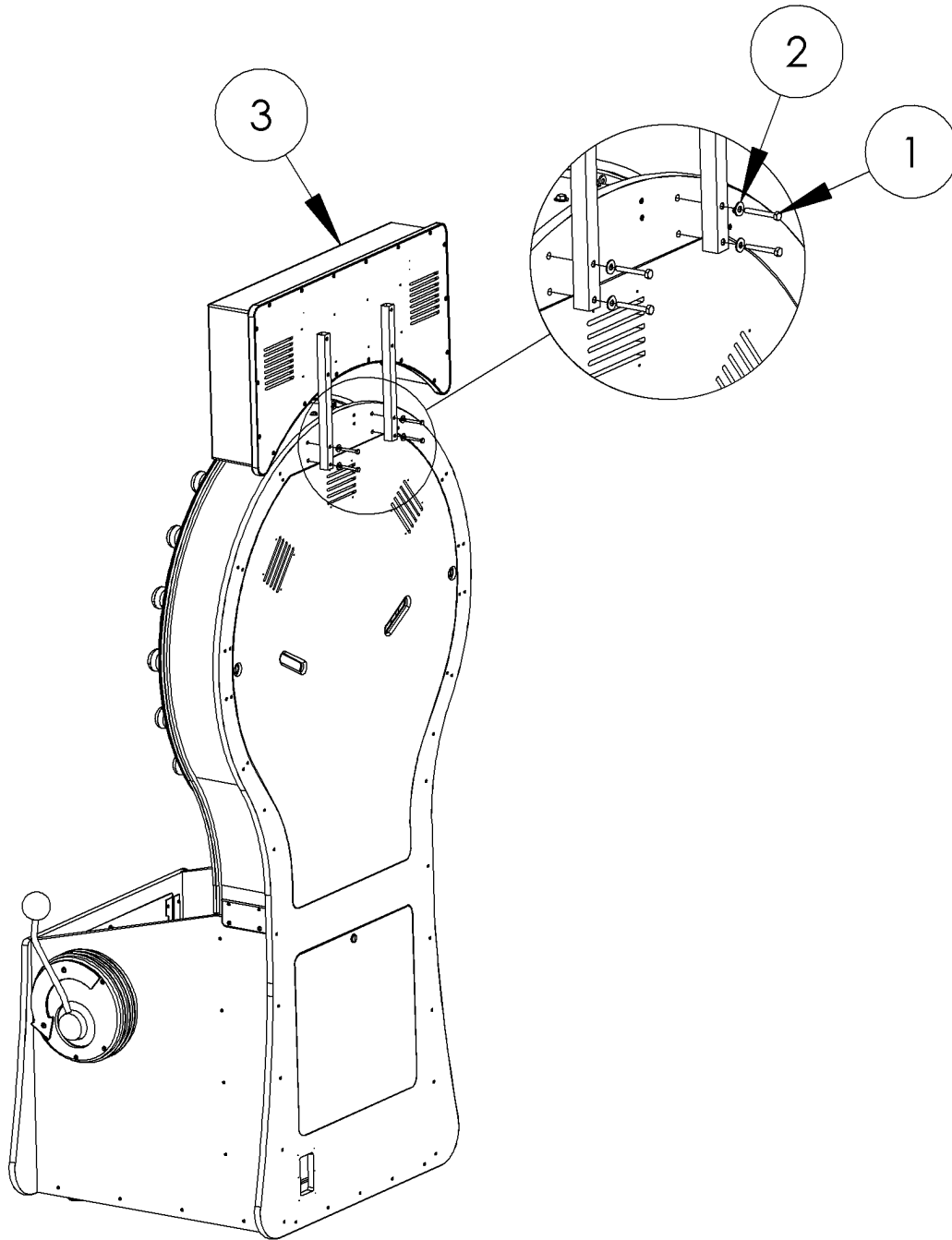

ITEM NO.	PART NO.	DESCRIPTION	QTY.
1	6082	1/4-20 x 2 Hex Head Machine Bolt	4
2	6075	1/4 x 3/4 FLAT WASHER	4
3	PW3032X	MARQUEE ASSEMBLY	1

MARQUEE ELECTRICAL SETUP

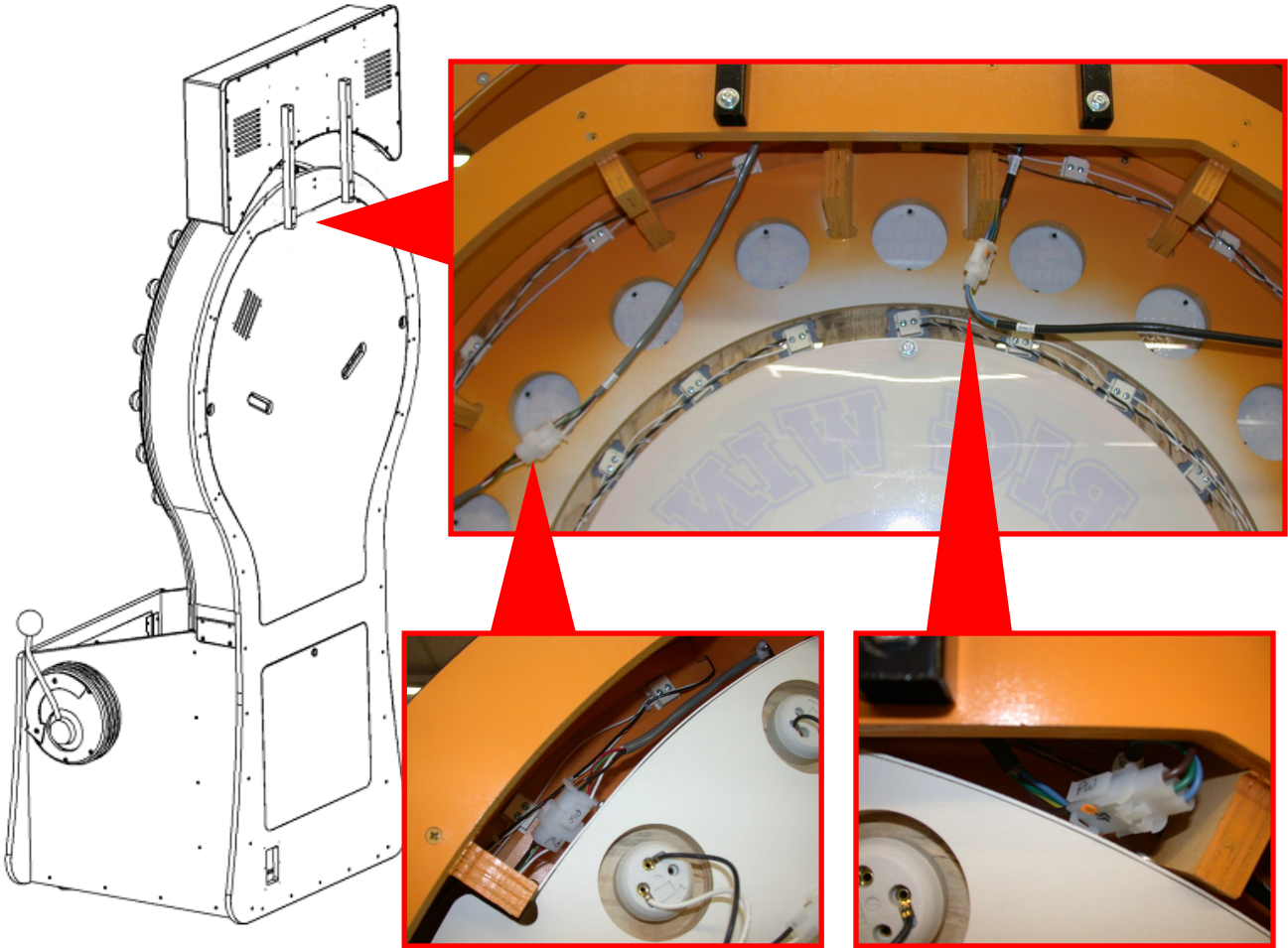

GAME SETUP LOCATION

The sizes shown on this diagram will help you determine the area required for your game, and where you might want the game to be placed.

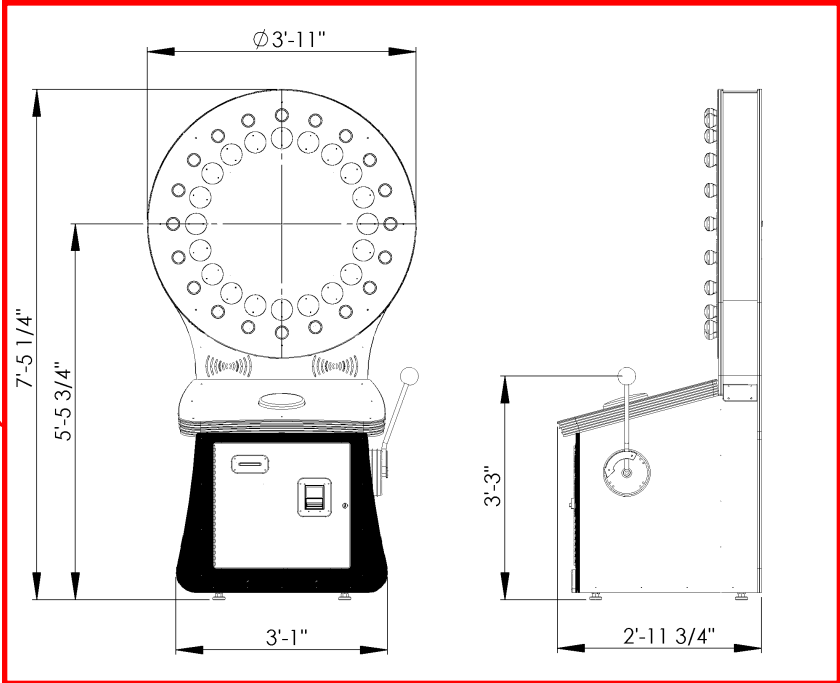

GAME SETUP AND FEATURES

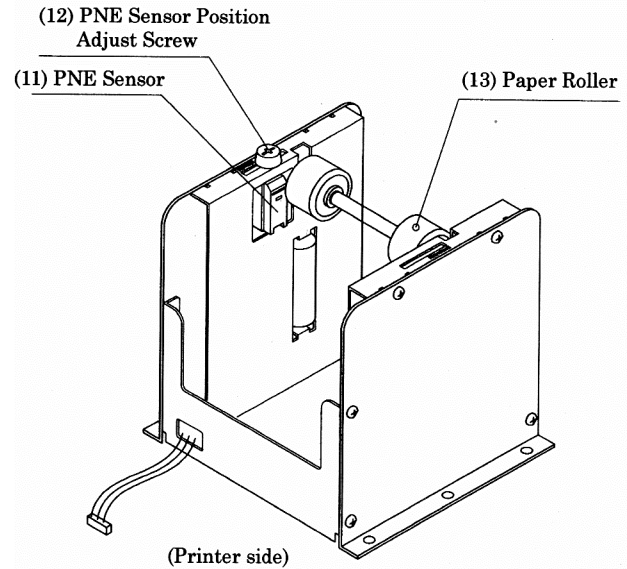
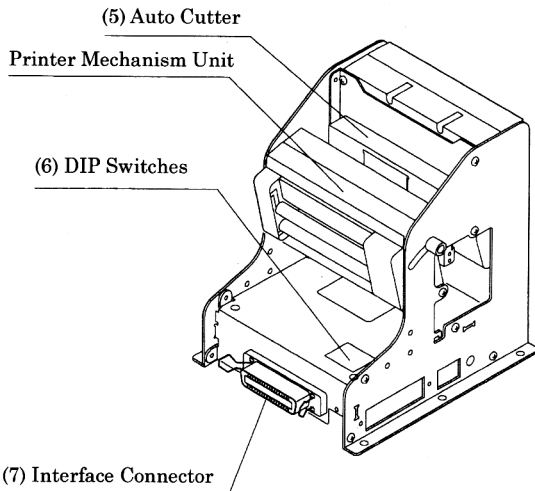
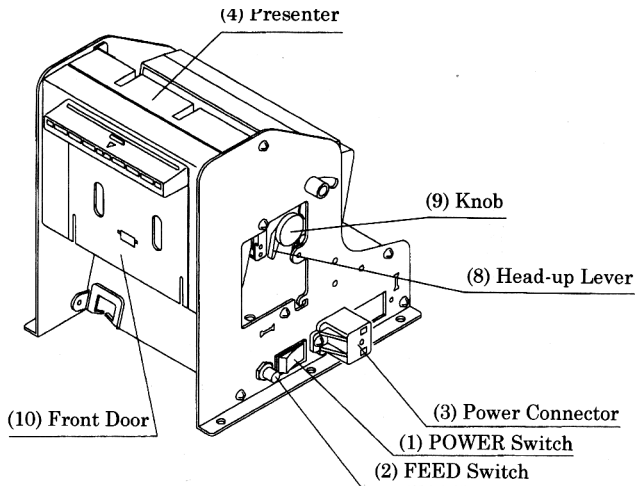

- (1) POWER switch
 - (a) Turns on/off the power for the printer/presenter unit.
 - (b) The Power switch can be mounted either side of the unit.
- (2) FEED switch
 - (a) Feeds the paper to exit the paper.
- (3) Power Connector
 - (a) Connects to the AC adapter.
 - (b) Power connector can be mounted at any of 6 locations.
- (4) Presenter
 - (a) Feeds the paper roll.
- (5) Auto Cutter
 - (a) Automatically cuts the printed paper.
- (6) DIP Switches
 - (a) Do not adjust.

- (7) Interface connector
 - (a) Connects to a communication cable
- (8) Head-up Lever
 - (a) Used when inserting the paper or exiting the paper.
- (9) Knob
 - (a) Use this to manually feed the paper.
- (10) Front Door
 - (a) Open this door to remove remaining paper.
- (11) PNE
 - (a) Detects that the paper is running out.
- (12) PNE Sensor position adjust screw
 - (a) Use to adjust remaining amount of paper.
- (13) Paper roller
 - (a) Holds the paper roll.

GAME SETUP AND FEATURES

Inserting the Paper

⚠ CAUTION:

- 1) Be sure to use the specified paper roll.
- 2) Use of non-specified paper may not guarantee the print quality, printing head life, presenter operation, and so on.
- 3) Do not insert a ragged or dog-eared end of the paper roll, because it could result in a paper jam or insertion error.

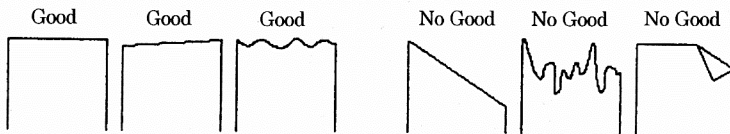

1. Cut the front end of the paper roll almost at a right angle.
2. Insert the paper roller of the paper holding unit into the core of the paper roll as shown in the figure on the next page.
3. Make sure the paper winding direction and put the paper roll onto the PHU.
4. Make sure that the power is turned on.
5. If there is still some paper remaining after a paper-out indication, eliminate the paper roll according to "4.4 How to Remove the Remaining Paper Roll."
6. Raise the head-up lever of the printer/presenter unit. (See the next page.)
7. Insert the front end of the paper roll straight into a paper insertion slot as shown in the figure on the next page, until the paper stops.
8. Put back the head-up lever. The paper is automatically pulled in by the platen roller to feed a constant amount of paper. (When auto-loading is enabled.) Remove the cut paper to enable printing.

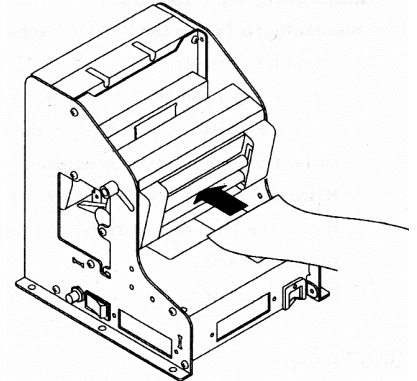
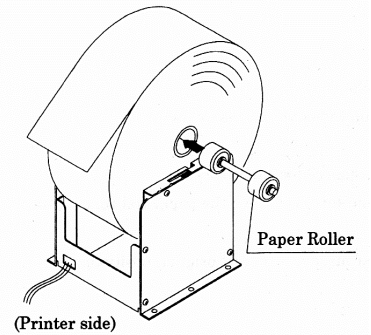

⚠ CAUTION:

- 1) If the paper roll is still slack, rewind the paper to remove the slack.
- 2) If the paper roll is tilted, raise the head-up lever to correct the paper roll position, or pull out the paper roll and set it again.
- 3) Do not hold or press the paper roll while printing, because it could cause a paper jam.
- 4) After the paper is set, the printer is made ready to start printing. Note that if data is remaining in the buffer, the printer will start printing after the paper is set.

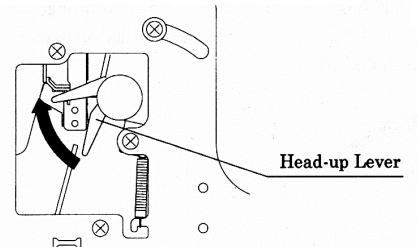

How to Remove Remaining Paper Roll

1. Raise the head-up lever of the printer/presenter unit.
2. Gently pull out the paper from the printer/presenter unit. If the paper roll is still remaining, cut it just before the paper insertion slot before pulling it out.

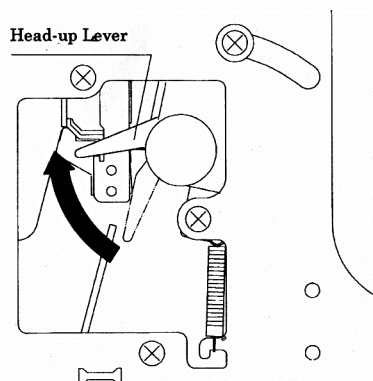

⚠ CAUTION:

- 1) Never take out paper with the head-up lever lowered, because it could damage the printing head.
- 2) The printer mechanism may be very hot just after printing, so be duly careful.

GAME SETUP AND FEATURES

Eliminating a Jam in the Presenter

1. Turn off the power.
2. Open the front door by pulling while pressing on the knob (see the figure).
3. Manually turn the roller until all paper is removed from the paper passage.
4. If a jam occurs between the auto-cutter and the presenter, with tweezers or similar, remove the paper roll with the utmost care.
5. Firmly close the front door.

CAUTION:

If the presenter rollers do not spin, do not apply extra force as this could break the mechanism.

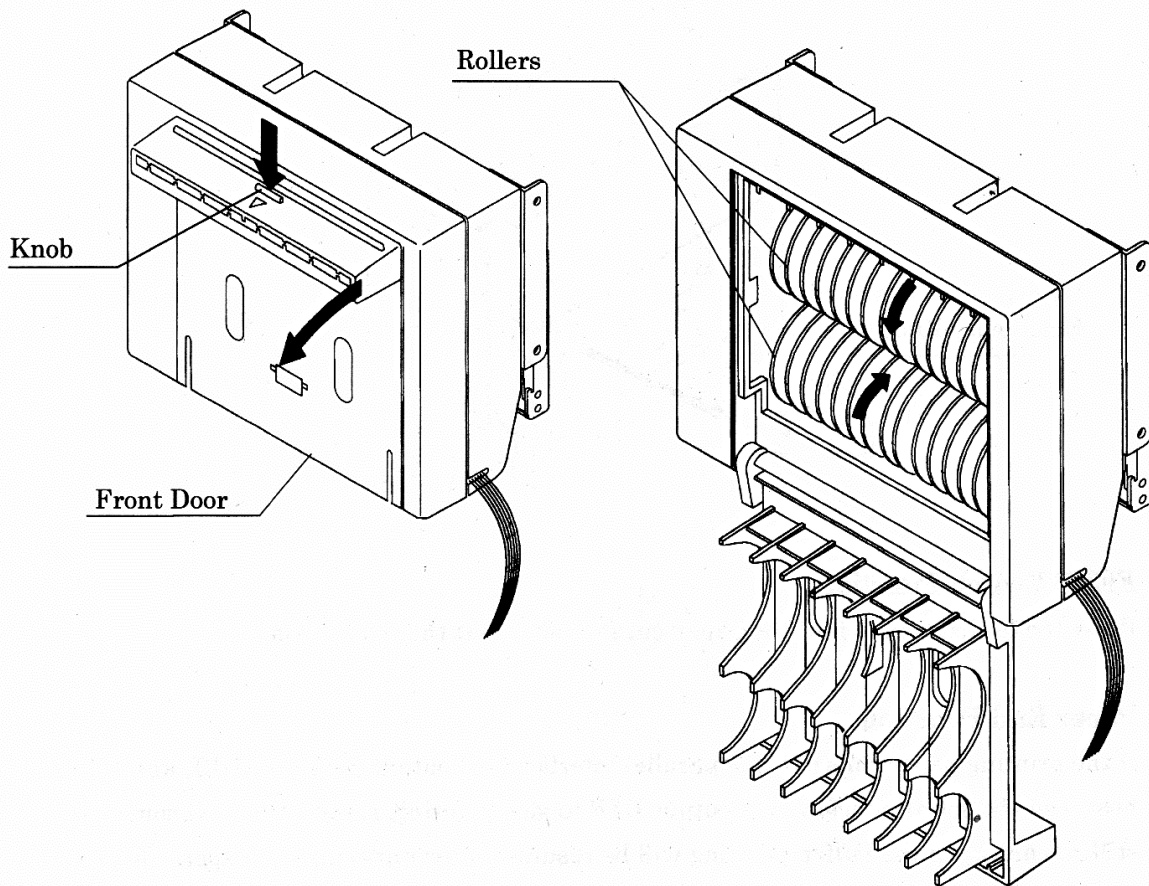

GAME SETUP AND FEATURES

Eliminating the Paper Jam

Eliminating a Jam in the Printer Mechanism

1. Turn off the power.
2. Cut the paper roll near the paper insertion slot.
3. Move the knobs on both sides in the direction indicated by the arrows to detach the auto cutter from the printer mechanism.
4. Raise the head-up lever to detach the head from the platen roller.
5. Rotate the knob of the printer mechanism and totally remove the paper roll that is left in the paper passage.
6. Lower the head-up lever to return the printer mechanism to its original position.

CAUTION:

- 1) The printer head gets very hot. Do not attempt any maintenance directly after printing.
- 2) When you wish to remove the unused portion of the paper, do not touch the hot surface of the printer head with your bare hands or a piece of metal.

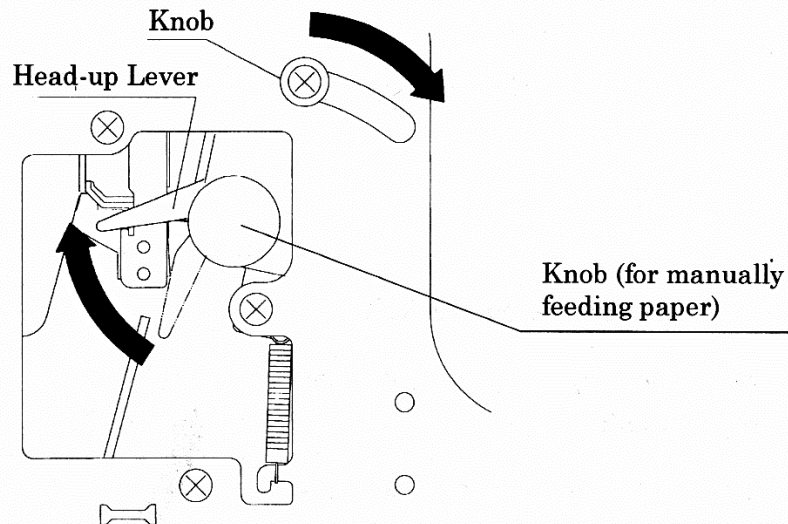

GAME SETUP AND FEATURES

Releasing a Locked Cutter

When the auto-cutter locks up and fails to cut paper, follow these steps to solve the problem.

1. Remove the paper from the paper passage as described in "4.5 Eliminating the Paper Jam".
2. Turn on the power. The auto cutter initialization begins and the cutter returns to its home position.
3. If the cutter does not return to its home position after the power has been turned on, do the following. Turn off the power, and return the auto cutter blade to its home position by turning the emergency knob of the auto cutter in the direction indicated by the arrow.
4. With tweezers or similar, totally remove remaining paper from the cutter blade area.

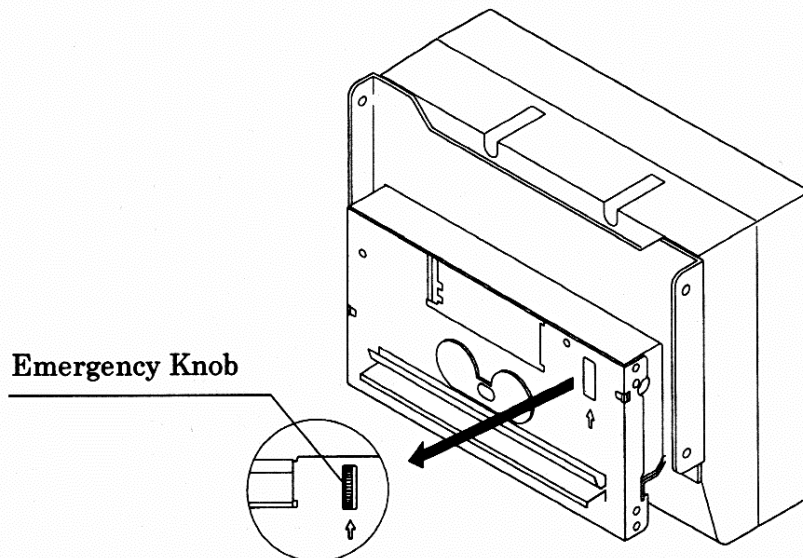

FEED Switch Function

Press the feed switch to feed the paper, cut it, and output the cut portion.

Paper End Function

If the printing paper runs out, the parallel interface will output BUSY, FAULT, and PE to the host, and the serial interface will output DTR to stop printing, respectively. • If some data are still remaining in the buffer, printing will be resumed after replacing the paper. Replace the paper according to "4.3 Inserting the Paper." After replacing the paper, cancel BUSY (DTR), FAULT, and PE outputs. For details, see "4.10 Near Paper End Function."

GAME SETUP AND FEATURES

Hopper Option:

If the hopper is installed, you will need to fill it with Dino tokens before operating the game. To fill the hopper, open the front door and pull the printer shelf until the drawer is completely open. There is a hole located in the back of the shelf to pour the tokens into.

It is important to check the amount of tokens in the hopper as there is no indication from the hopper when the tokens are low or out. If during operation the hopper runs out of tokens, the hopper will run for five seconds, shut off not dispensing any tokens, and record internally that it owes a token. It will continue to do this for each customer that wins a token until the hopper is refilled. When the hopper is filled again you must turn the game on and off or the next player that wins a token will be rewarded with all owed tokens and the token they just won.

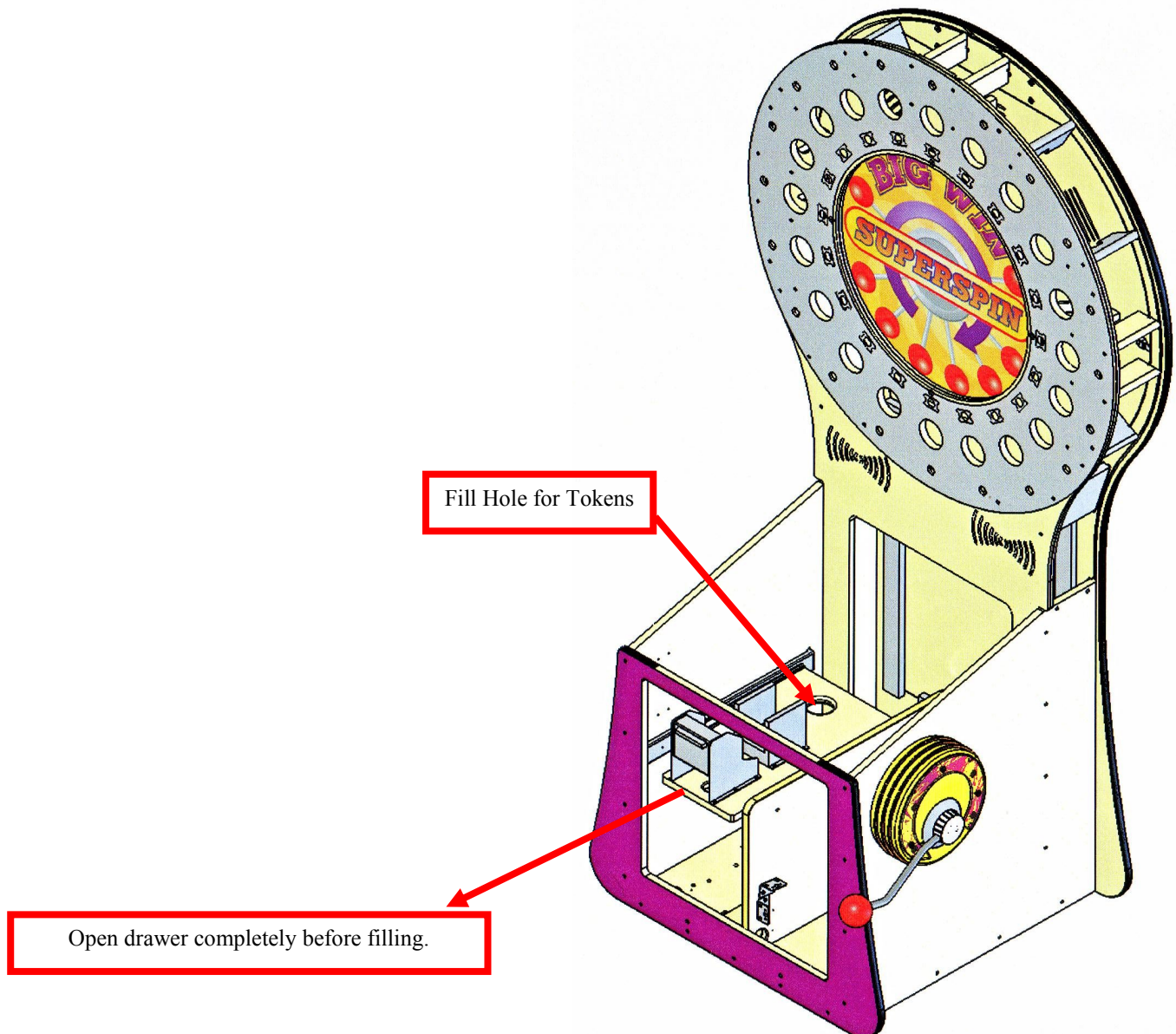

ELECTRICAL COMPONENTS

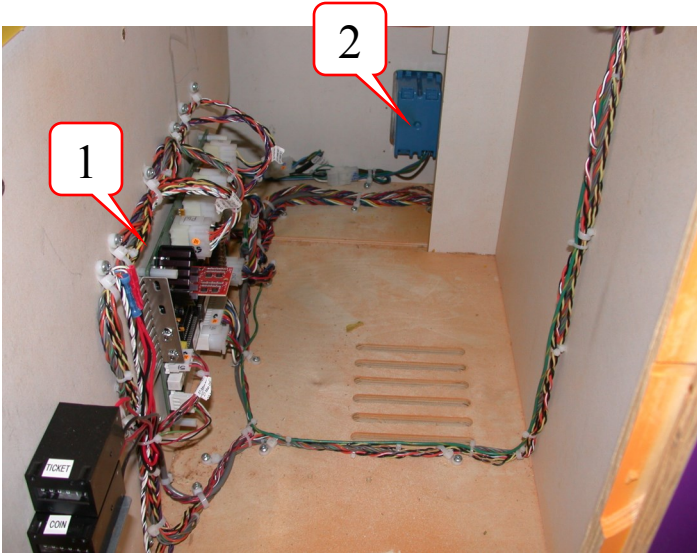

Front view of cabinet

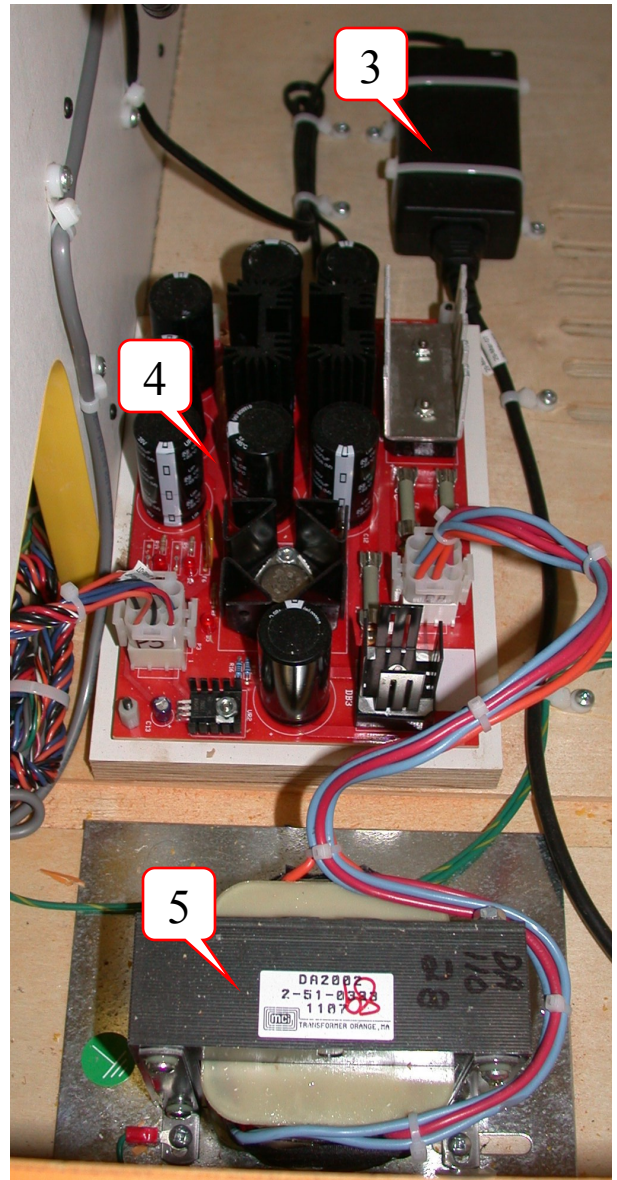
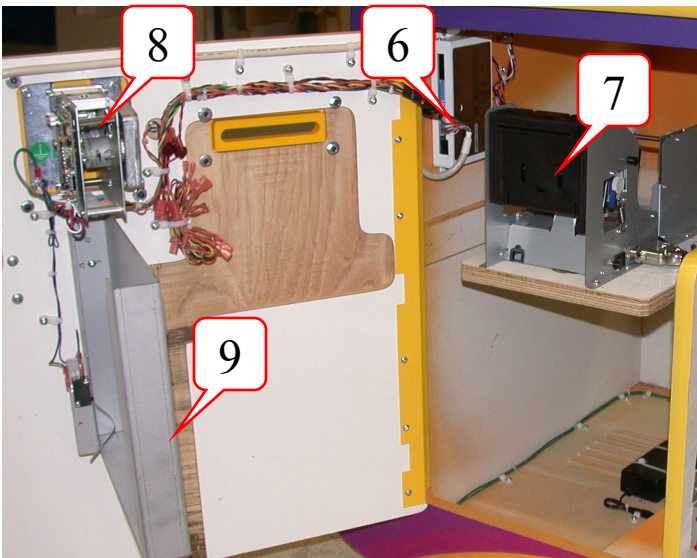

1	PW2034X	Main Board
2	SX2007X	Power module (5MDQ)
3	PW5001	Printer AC adaptor Power Supply
4	DA2001X	Main power supply
5	DA2002X	Main transformer
6		Card swipe logic
7	PW5000	Citizen PPU-231 Printer
8	HH5005D	Ticket dispenser
9	PW1024	Ticket bin

ELECTRICAL COMPONENTS

Rear view of cabinet

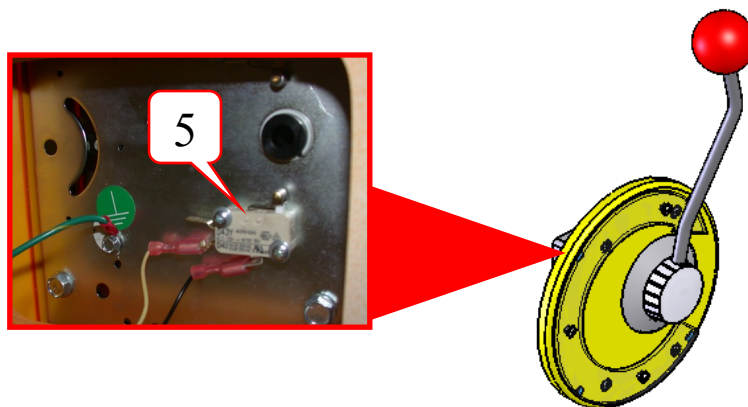
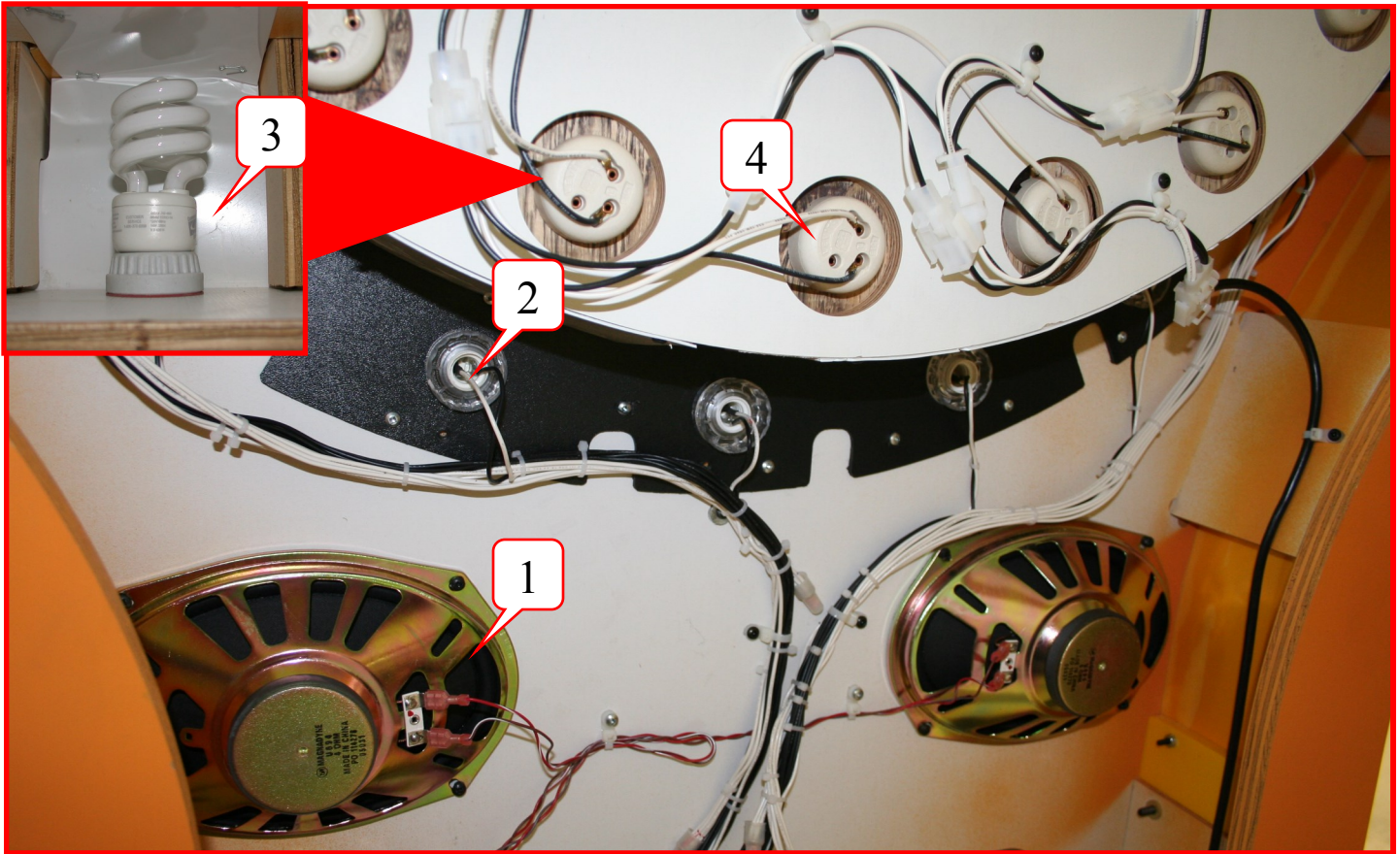

1	AR2007	Speaker
2		
3	8690	Fluorescent Light Bulb
4	PW2130X	Light Socket Assembly - Inner Ring
5		Pull Arm Switch

PROGRAMMING OF BIG WIN-SUPER SPIN (CEC)

Programming

There are 3 buttons that are used for the programming of Big Win Super Spin.

1. Hand Push Button –See Image #1
2. Programming Button –See Image #2
3. Pull Arm - See Image #3

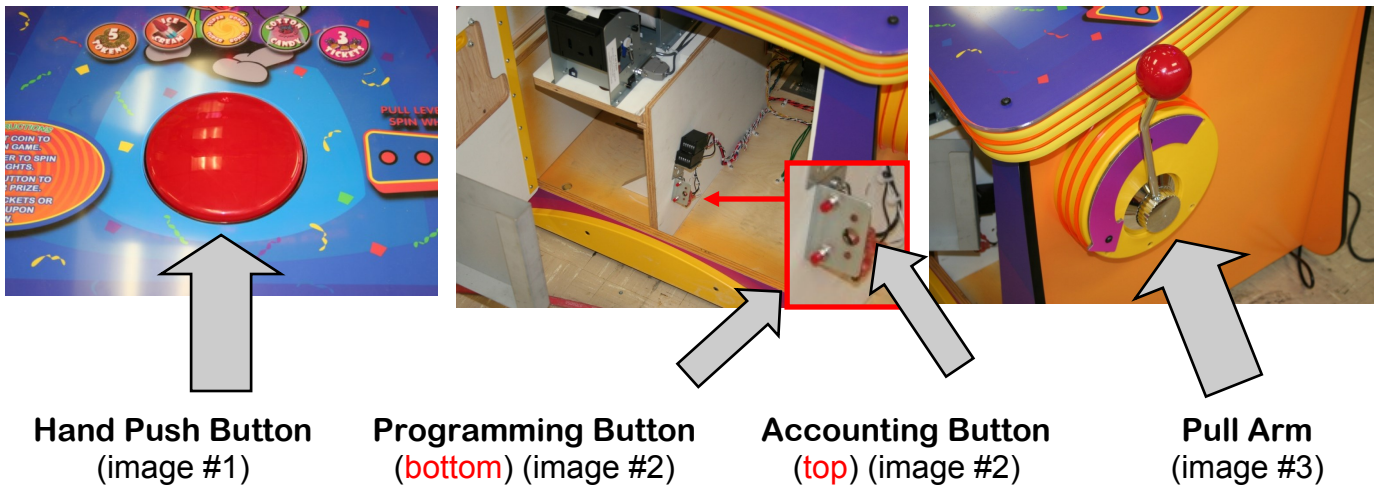

The game must be attract mode before it will enter programming. You enter programming mode by pressing and holding the programming button (image #2) for one second.

To change an option you press the hand button (image #1) to increment that option. Each option is displayed by a light on the light ring. For each window values, the light that it effects will be lit, for the others a non-prize light will be lit. Each additional press will increment the option. When it reaches the maximum value (see below), it will loop back to the minimum value. The value is displayed in the Bonus Display.

Once you have changed (or viewed) the option, you need to pull the arm. This will take you to the next option. If you pull the arm again you will be taken to the next available option. When the option list runs out, you will be returned to the first option.

To exit programming mode you need to press and hold the programming button (image #2) for one second and the game will reboot using the newly changed options.

The option list is as follows:

- 1) Coin Cost (left of top)
minimum=1, maximum=10, default=1
- 2) Window Big Bonus (top)
min=1, max=59, default=58
- 3) Window Cotton Candy (top right)
min=1, max=59, default=48
- 4) Ice Cream (right)
min=1, max=59, default=50
- 5) Balloon (bottom right)
min=1, max=59, default=48
- 6) 100 tickets (bottom)
Min=1, max=59, default=58
- 7) Cotton Candy (bottom left)
Min=1, max=59, default=48
- 8) Ice Cream (left)
min=1, max=59, default=50
- 9) Balloon (top left)
min=1, max=59, default=48
- 10) Bonus Value (right of top)
min=10, max=900, default=250
- 11) Store ID (100's column) [see pages 15-18](#)
min=0, max=9, default=0
- 12) Store ID (10's column) [see pages 15-18](#)
min=0, max=9, default=3
- 13) Store ID (1's column) [see pages 15-18](#)
min=0, max=9, default=1
- 14) Factory Reset (second right of top)
0=normal, 1=reset

PROGRAMMING OF BIG WIN-SUPER SPIN (CEC)

Programming (cont'd)

There are 3 buttons that are used for the programming of Big Win Super Spin.

1. Hand Push Button –See Image #1
2. Programming Button –See Image #2
3. Pull Arm - See Image #3



Hand Push Button
(image #1)

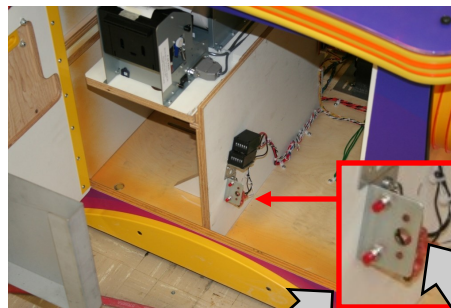

Programming Button
(bottom) (image #2)



Accounting Button
(top) (image #2)



Pull Arm
(image #3)

The game must be attract mode before it will enter 'Accounting Mode'. You enter 'Accounting mode' by pressing and holding the Accounting button (image #2-top button) for one second. A ticket will print out showing what prizes have been awarded. See image #4 below. The first row of numbers shows the total prizes awarded, the next line is the Super Bonus (12 o'clock position), then Cotton Candy (1 o'clock position), and so on continuing in a clock-wise fashion.

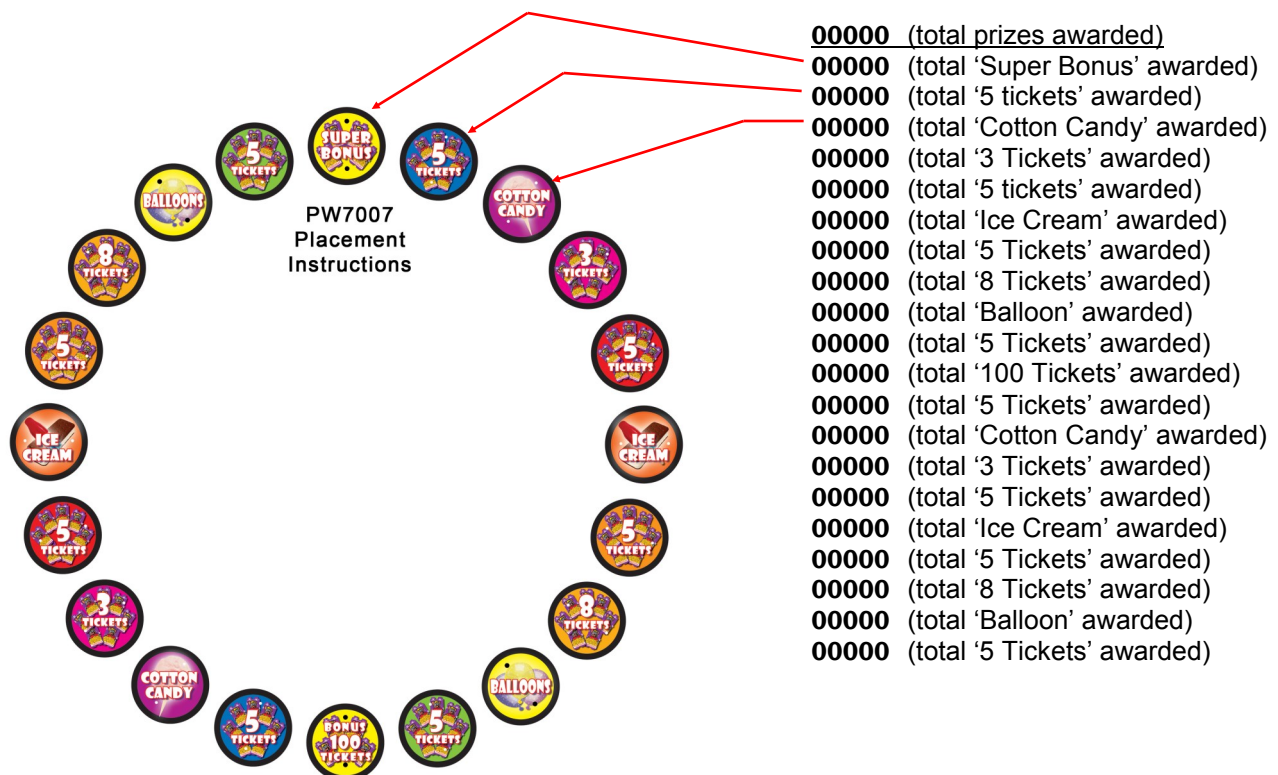

PROGRAMMING OF BIG WIN-SUPER SPIN (CEC)

031	Tyler, TX	095	Chino, CA	332	Albuquerque, NM
032	Houston FM 1960, TX	096	Indianapolis-Castleton, IN	333	Vancouver, WA
033	Copperfield, TX	097	Naperville, IL	334	Ann Arbor,MI
034	Oaklawn, IL	098	San Antonio-Ingram ,TX	335	Grand Rapids,MI
035	Lewisville, TX	099	Herndon, VA	336	Saginaw ,MI
038	Rockwall, TX	101	Parma, OH	337	Pontiac, MI
039	Charlotte, NC	103	Sterling Heights, MI	338	Burlington, WA
041	Bakersfield, CA	105	Humble, TX	339	Albuquerque/Cottonwood, NM
042	Fresno, CA	108	Redwood City, CA	340	Clarksville, IN
043	Visalia, CA	109	Burbank, CA	341	Kokomo, IN
045	Oceanside, CA	111	Louisville ,KY	342	Vernon Hills, IL
047	Springfield, IL	115	Lonetree, CO	345	Bloomington, IL
048	Alexandria, LA	117	Kennesaw, GA	346	Indianapolis-Greenwood ,IN
049	Lancaster, CA	118	Manassas, VA	348	Hobart, IN
050	Annapolis, MD	121	Winston Salem, NC	349	Batavia, IL
053	Crystal Lake, IL	200	Modesto, CA	353	Palm Desert, CA
054	Melrose, IL	300	Olympia, WA	355	Valencia, CA
055	Knoxville, TN	301	Fort Smith, AR	356	Victorville, CA
056	Richmond, VA	302	Fayetteville, AR	357	Lakewood, CA
058	Tinley Park, IL	303	Little Rock, AR	358	Torrance, CA
059	Streamwood, IL	304	North Little Rock, AR	359	Dearborn, MI
060	Evansville, IN	305	Bellevue, WA	360	Peoria, IL
062	Jacksonville Regency, FL	306	Kent, WA	362	Cerritos, CA
063	Kedzie, IL	307	Las Cruces, NM	363	Hayward, CA
064	Charlotte, NC	308	West Las Vegas, NV	364	N. Fresno, CA
065	Pensacola, FL	309	Wichita Falls, TX	365	Nashville/Cool Springs, TN
066	Jacksonville O-Park, FL	310	Denton, TX	367	Ladera Heights, CA
067	K. C. Metcalf, KS	311	SE Las Vegas, NV	368	Clarksville, TN
068	Nashville Madison, TN	314	Henderson, NV	370	El Centro, CA
071	Potomac Mills, VA	315	Las Vegas, NV	371	Foothill Ranch, CA
072	Alexandria, VA	316	Reno, NV	372	Birmingham Parkway, AL
073	Matteson, IL	318	Salinas, CA	373	Gilroy, CA
074	Nashville Antioch, TN	319	Greenbay, WI	374	Jacksonville, NC
077	K. C.Antioch, MO	320	Thousand Oaks, CA	375	San Bernardino, CA
079	Towson, MD	321	Newark, CA	376	Hemet, CA
080	Canton, MI	322	Dublin, CA	377	Lynwood, CA
081	Irving, TX	323	Flint, MI	380	Durham, NC
082	K. C. Noland Road, MO	324	Pasadena, CA	381	Concord, NC
084	Fairfax, VA	325	Fullerton, CA	382	Hickory, NC
085	Rochester Hills, MI	326	Lansing, MI	383	Spartanburg, SC
087	Laurel, MD	327	Portage,MI	385	N. Charleston, SC
090	White Settlement, TX	329	Citrus Heights, CA	386	Goldsboro, NC
092	Waldorf, MD	330	Birmingham Vestavia, AL	387	Rocky Mount, NC
094	Joliet, IL	331	Novi, MI	390	Monrovia, CA

PROGRAMMING OF BIG WIN-SUPER SPIN (CEC)

393	Moreno Valley, CA	450	Snyder Plaza, PA	516	Hamburg, NY
399	Rohnert Park, CA	451	Northridge, CA	517	Rochester, NY
401	Gaithersburg, MD	452	Philly-Levittown, PA	518	Mays Landing, NJ
402	Silver Spring, MD	453	Ventura, CA	519	West Long Branch, NJ
403	Diamond Point Plaza, MD	454	Corpus Christi, TX	520	Albany, NY
404	San Jose, CA	455	Montgomeryville, PA	521	Vestal, NY
405	La Mesa, CA	456	Skokie, IL	522	Brooklyn, NY
406	Huntington Beach, CA	457	Lowell, MA	523	Bronx, NY
407	Corona, CA	459	Worcester, MA	524	Middletown, NY
409	Diamond Bar, CA	460	St Petersburg, FL	525	East Hanover, NJ
410	Sacramento, CA	461	West Hills, CA	526	Syracuse, NY
411	Simi Valley, CA	462	Carson, CA	527	Hempstead, NY
412	Catonsville, MD	463	Mattatuck Plaza, CT	528	Burlington, NJ
413	Covina, Ca	464	Attleboro, MA	530	Butler, PA
414	Murrieta, CA	465	Torrance, CA	531	Rockville, MD
415	San Bernardino, CA	467	E. Hartford, CT	532	Largo, MD
416	Arlington, TX	468	Orange, CT	533	Wilkes Barre, PA
417	San Antonio Military, TX	470	Newington-Hartford, CT	534	Johnstown, PA
418	Sun Valley, CA	471	Newington, NH	535	Bridgeville, PA
419	Rancho Cucamonga, CA	472	Manchester, NH	536	Erie, PA
420	Brandon, FL	474	Glen Burnie, MD	537	Monroeville, PA
421	Costa Mesa, CA	475	Roseville, MI	538	Downingtown, PA
422	Garden Grove, CA	476	Springfield, MA	539	Reading, PA
423	Norwalk, CA	478	Danvers, MA	540	Lancaster, PA
424	Hialeah, FL	479	Natick, MA	541	Scranton, PA
426	Lakeland, FL	480	Middletown, NJ	542	Union, NJ
428	El Monte, CA	481	Deptford, NJ	543	King of Prussia, PA
429	Granada Hills, CA	483	Philadelphia-Springfield, PA	544	North Hills, PA
430	Tampa Carrollwood, FL	485	N. Bergen, NJ	545	Fredericksburg, VA
433	Pembroke Pines, FL	487	Edison, NJ	547	Mayfield Heights, OH
434	Sunrise, FL	488	Burlington, MA	548	Virginia Beach, VA
435	N Miami, FL	489	Wayne ,NJ	552	Boardman, OH
436	Clearwater, FL	494	Staten Island, NY	553	Akron, OH
437	Philly-Roosevelt, PA	496	Patchogue, NY	554	South Toledo, OH
438	Kendall, FL	498	Cherry Hill, NJ	555	Dayton, OH
439	National City, CA	499	Hicksville, NY	556	North Toledo, OH
440	Pico Rivera, CA	500	Brick , NJ	557	Columbus - S.W. ,OH
441	San Diego, CA	501	Paramus, NJ	558	Colorado Springs North, CO
442	Placentia, CA	502	Bel Air, MD	559	Cleveland, OH
443	Mira Mesa, CA	504	Commack, NY	560	Mobile, AL
444	San Bruno, CA	505	Poughkeepsie, NY	561	Cincinnati Colerain, OH
445	Fontana, CA	510	West Windsor, NJ	562	Gulfport, MS
446	Bell , CA	511	West Islip, NY	563	Cordova, TN
447	La Mirada, CA	512	Bridgewater, NJ	564	Horn Lake, MS
448	Allentown, PA	513	Queens, NY	565	San Antonio Stone Oak, TX

PROGRAMMING OF BIG WIN-SUPER SPIN (CEC)

566	Hattiesburg, MS	625	Portland, ME	706	Houma, LA
567	Bowling Green, KY	627	Kelso, WA	708	Grand Junction, CO
568	Lincoln, NE	628	Charleston, WV	709	Lake Charles, LA
570	Texarkana, TX	631	Stockton, CA	710	Aurora, CO
571	Houston Meadows, TX	633	Roseville, CA	711	Superior, CO
572	Woodlands, TX	634	Glendale, CA	713	Southgate, MI
575	Houston Wesleyan, TX	635	Gastonia, NC	714	Indianapolis-Wash. Sq., IN
576	Lake Jackson, TX	636	Raleigh, NC	715	Lafayette, LA
577	College Station, TX	637	Greensboro, NC	716	New Orleans-Veterans, LA
579	Ft. Worth, TX	638	Asheville, NC	717	Arvada, CO
580	Valley View, TX	645	Warwick, RI	718	Orlando, FL
581	Victoria, TX	646	New Hartford, NY	719	Orlando West, FL
582	Abilene, TX	650	New London, CT	720	Bradenton, FL
583	San Antonio Forum, TX	651	Meriden, CT	721	Englewood, CO
584	Firewheel - North Garland, TX	652	Richmond, VA	722	East Orlando, FL
585	Houston/Willowbrook, TX	654	Sterling/Dulles, VA	724	LaCrosse, WI
586	Austin/Arbor Walk, TX	655	Cedar Falls, IA	725	Miami - South Dade, FL
589	Anchorage ,AK	656	Sioux City, IA	726	Racine, WI
591	Houston Gulfgate, TX	657	Sumter, SC	728	Janesville, WI
592	Houston Webster, TX	658	Florence, SC	729	Atlanta Cumberland, GA
593	San Antonio Bandera, TX	662	Colorado Springs South, CO	731	Houston Memorial, TX
595	Hulen, TX	663	Johnson City, TN	732	Killeen, TX
596	Grand Prairie, TX	664	Murfreesboro, TN	733	Omaha Dodge, NE
597	Allen, TX	665	Olathe, KS	735	Houston Sugarland, TX
598	Katy, TX	667	Jackson, TN	736	Dublin, OH
599	Longview, TX	668	Jonesboro, AR	737	Columbus - Macsway, OH
600	N. Point (Alpharetta), GA	670	Columbus, IN	738	Sharonville, OH
601	Atlanta Jonesboro, GA	673	Lafayette, IN	740	Canton, OH Training Store
602	Conyers, GA	681	Orlando Spring Oaks, FL	742	Springfield, MO
603	Appleton, WI	682	Boca Raton, FL	743	Mentor, OH
604	Madison, WI	684	N. O. Cypress Plaza, LA	745	Niles, OH
605	Savannah, GA	685	Darien, IL	746	Mansfield, OH
606	Indianapolis-Lafayette, IN	686	Villa Park, IL	748	Columbia, MO
607	Atlanta Merchants Walk, GA	687	Riverpoint Center , IL	749	Joplin, MO
608	Montgomery, AL	688	Arlington Heights, IL	751	Dartmouth, MA
609	Baton Rouge Sherwood, LA	690	Stuart (Jensen Beach), FL	752	Methuen, MA
611	Atlanta Norcross , GA	691	Fairmont Parkway, TX	753	Leominster, MA
612	Athens, GA	693	Slidell, LA	755	Everett, MA
613	Douglasville	694	Gurnee, IL	759	Dover, DE
614	Macon, GA	700	Port Huron, MI	761	Santa Maria, CA
615	Atlanta/Fayetteville, GA	701	Decatur, AL	762	Doylestown, PA
616	Atlanta/Buford, GA	702	Greely, CO	763	Greensburg, PA
617	Albany, GA	703	Dothan, AL	767	Baton Rouge, LA
620	Yuma AZ	704	Tuscaloosa, AL	770	Frederick, MD
621	Phoenix, AZ	705	Huntsville, AL	771	Salisbury, MD

PROGRAMMING OF BIG WIN-SUPER SPIN (CEC)

772 Hagerstown, MD	888 OKC Towne South, OK
780 Ocala, FL	889 OKC NW Highway, OK
784 Vista, CA	891 Tulsa Crossing Oaks, OK
785 Orange, CA	916 Fairview Heights, IL
786 Cupertino, CA	928 Midland, TX
788 Escondido, CA	930 Beaumont, TX
793 Burnsville, MN	931 Southbend, IN
794 Maple Grove, MN	933 Lubbock, TX
795 Blaine, MN	935 Austin - Ben White, TX
796 West St. Paul, MN	937 Amarillo, TX
797 Edina, MN	938 Springfield, OH
826 Troy, MI	939 Augusta, GA
827 Holland, MI	941 Muncie, IN
828 Walker, MI	942 Garland, TX
829 Muskegon, MI	943 Austin/Round Rock, TX
831 Windsor, ON	946 Ft. Wayne, IN
832 New Market, ON L3Y7R6	947 St. Louis W. County, MO
833 Whitby, ON	948 St. Louis St. Charles, MO
834 S. Edmonton, Alberta	949 Redbird, TX
836 W Mississauga, ON	950 Plano, TX
839 Greece, NY	954 Wilmington, DE
840 Amherst, NY	956 Cedar Rapids, IA
841 Brookfield, WI	957 Davenport, IA
842 Milwaukee, WI	958 West Des Moines, IA
843 West Allis, WI	959 Boise, ID
844 Mississauga, ON	960 Rockford, IL
845 Willowdale, ON	961 Topeka, KS
846 Cambridge ON	962 Wichita, KS
847 Langley/British Columbia	963 Lexington, KY
849 Nanuet, NY	964 Harrisburg, PA
850 West El Paso, TX	965 York, PA
852 East El Paso, TX	966 Charleston, SC
853 Brownsville, TX	967 Columbia, SC
854 Grapevine, TX	968 Greenville, SC
855 St. Louis - South County, MO	969 Chattanooga, TN
856 Waco, TX	970 Memphis, TN
857 Sherman, TX	971 North Memphis, TN
860 Sioux Falls, SD	972 Roanoke, VA
861 Rapid City SD	
865 Fort Collins, CO	
869 Columbus, GA	
870 Kingston, ON	
872 Regina , Saskatchewan	
873 Vaughan, ON	
874 Calgary, Alberta	

TROUBLESHOOTING

Troubleshooting

CAUTION

This game uses complex electronic components that are very sensitive to static electricity. Observe precautions below before handling these electronics. Failure to do so may void the warranty and damage electronic assemblies.

Before servicing electronics, turn off AC power to the game. Wait for capacitors to discharge.

DO NOT remove any of the components on the main board (e.g. compact flash and eproms) while the game is powered on. This may cause permanent damage to the parts and the main board.

Before touching or handling electronic assemblies, discharge static electricity on your body. To discharge this static, begin by connecting the line cord to a grounded outlet. Don't turn on the game. Next, touch the safety ground stud of the power supply chassis.

Store electronic assemblies in an anti-static area. Use anti-static bags to store or transport the game circuit boards.

Don't remove or connect electronic assemblies when cabinet power is on. Otherwise, you'll damage electronic assemblies and void the game's warranty.

After you complete maintenance or service, replace ground wires, shields, safety covers and install and tighten ground and mounting screw.

Fuses - Main Power Supply

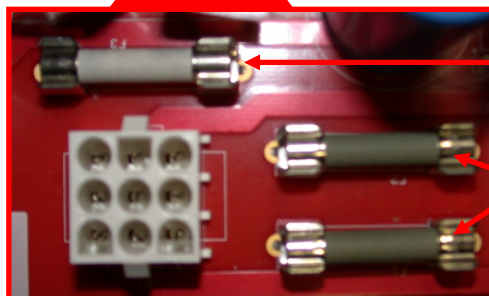
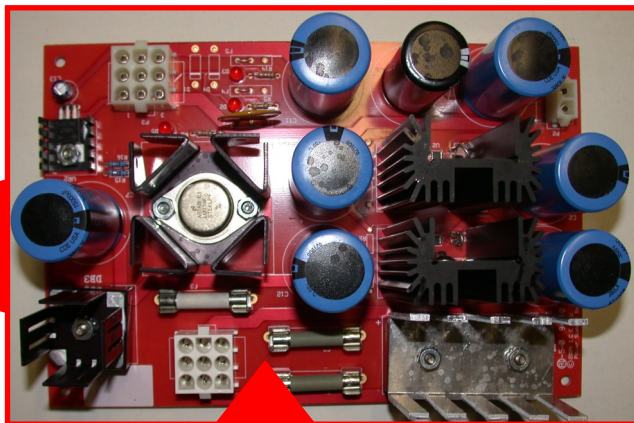
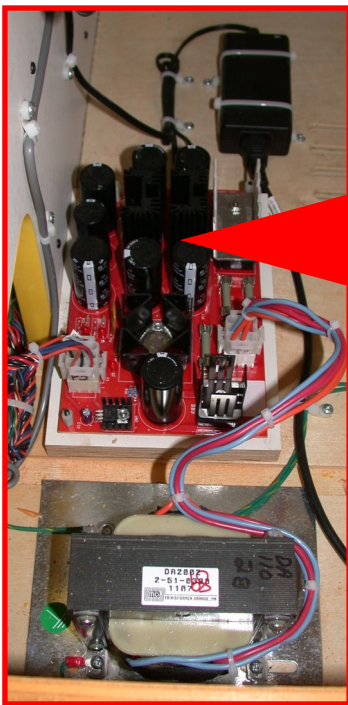

4 Amp/250V
F3

8 Amp/250V
F1&F2

TROUBLESHOOTING

Fuses - Main PCB

All fuses are slow blows.

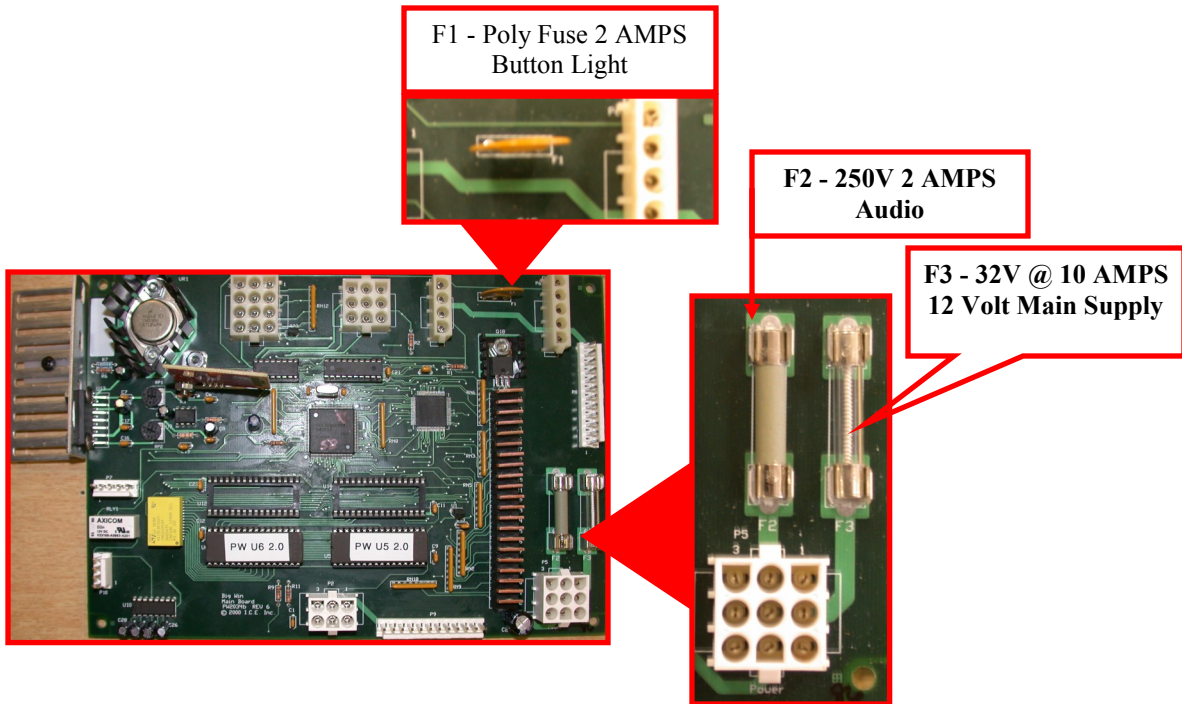

Adjusting Volume

To adjust volume, locate RP1 and RP2 next to the audio IC. Turn the potentiometer until the desired level is reached. See the diagram below.

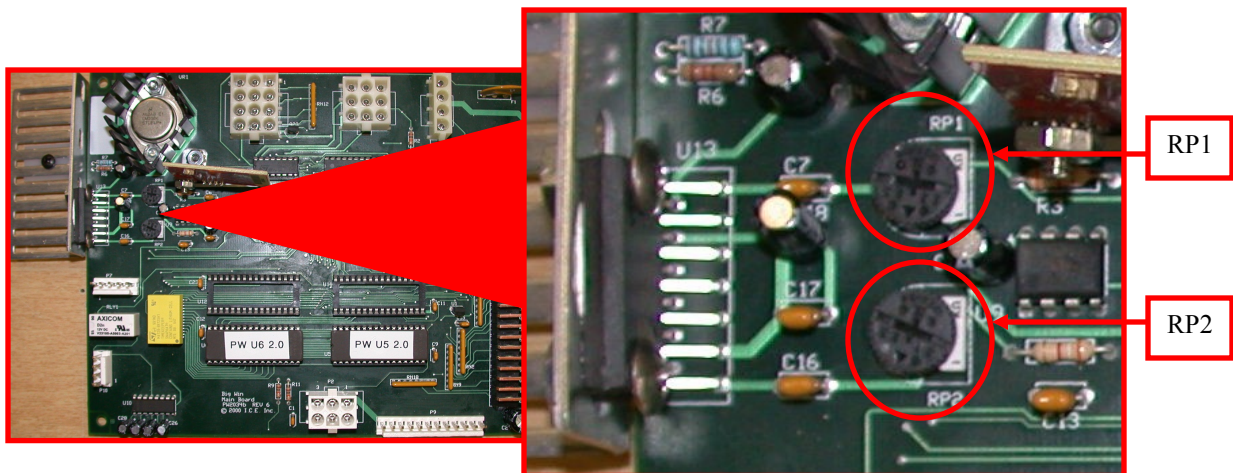

TROUBLESHOOTING

Light Bulb Replacement

All fluorescent light bulbs are replaced from the back of the machine. Access the back of the game and remove the defective light bulb as shown below. Make sure you use ICE part #xxxxxxx or equivalent.

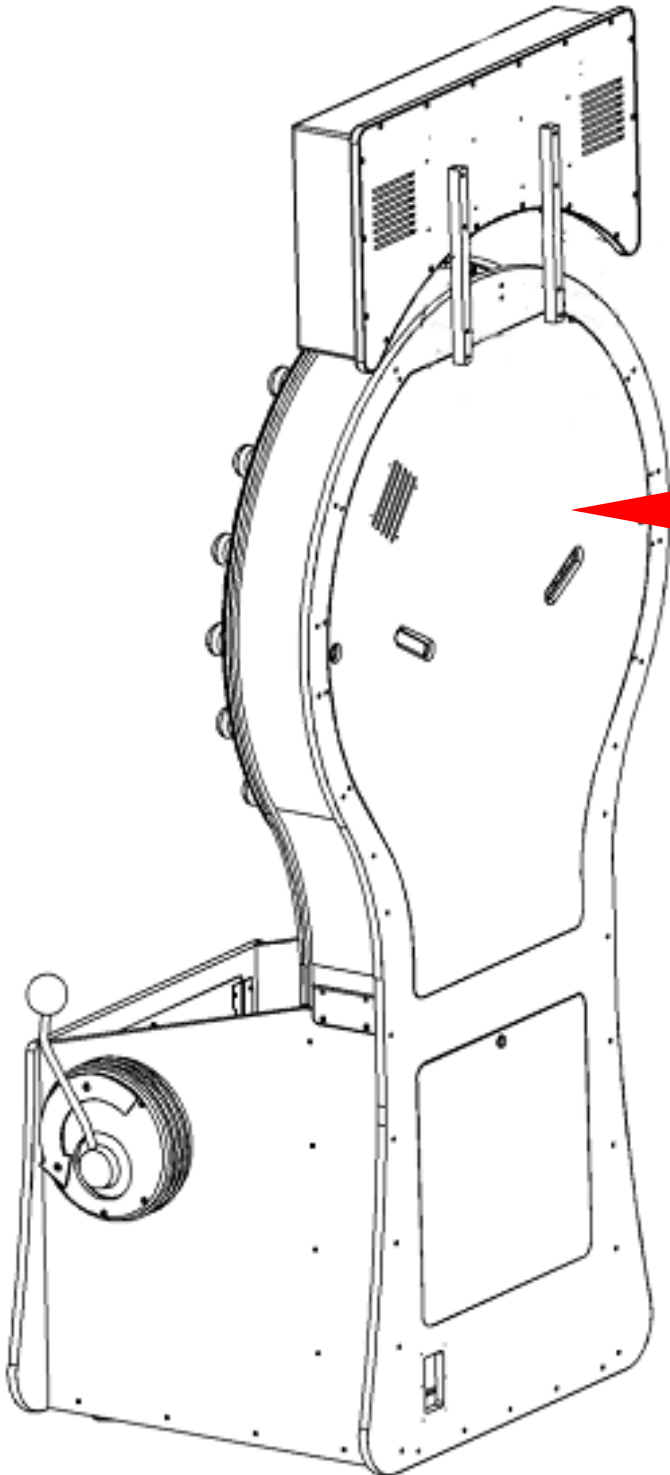

TROUBLESHOOTING

Light Bulb Replacement - Marquee Bulbs

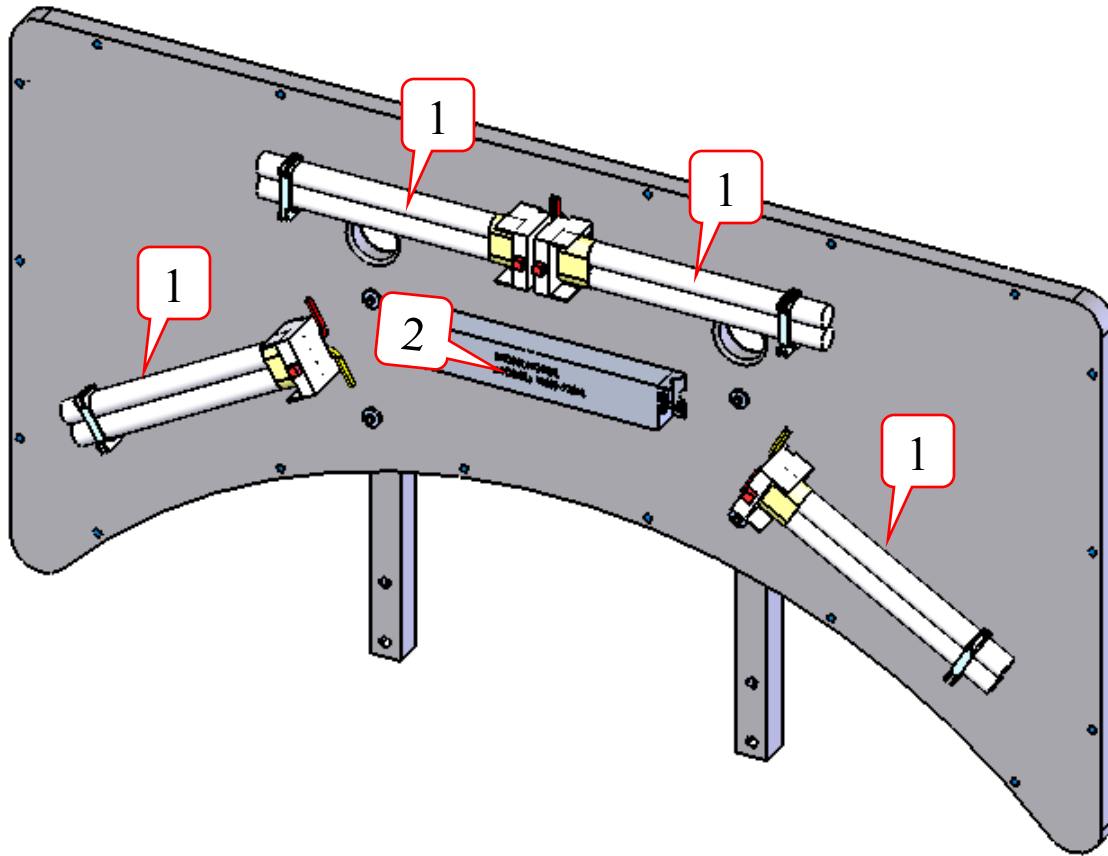

ITEM NO.	PART NO.	DESCRIPTION	QTY.
1	8453	Fluorescent bulb	4
2	PW8384X	Ballast	1

TROUBLESHOOTING

LED Bulb Replacement

LED's are very reliable and very rarely fail. If there is a unfortunate failure both the large and small front LED's are replaced in the same manner. Remove the cap by unscrewing the plastic cap counter-clockwise. Now remove the defective LED bulb by turning it counter-clockwise. Insert new LED bulb and install it clockwise. Replace the cap.

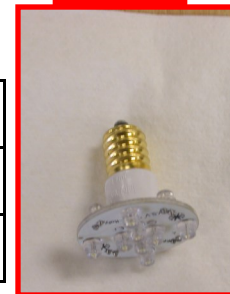

QTY	Part Number	Description
20	E00052	Large LED bulbs
20	E00053	Small LED bulbs

TROUBLESHOOTING

Control Panel LED Bulb Replacement

To gain access to the LED's located within the arrow, you must remove the top seven bolts and lift the top of the control panel off. From underneath the top you now can access the LED's.

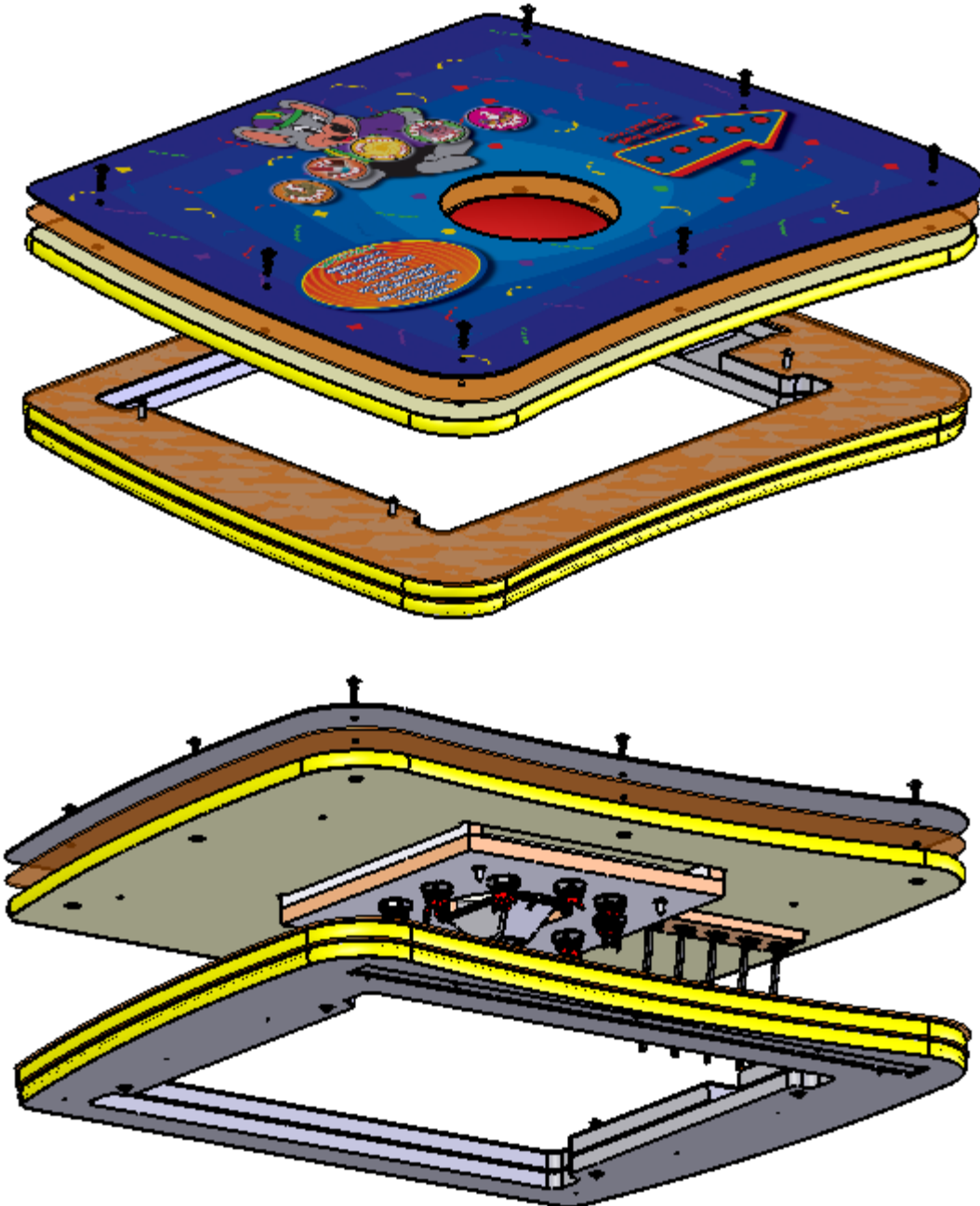

QTY	Part Number	Description
5	E00049	LED 1/4 Wedge Base
5	E01011	Bulb Socket

TROUBLESHOOTING

Lever Arm Top Ring Assembly

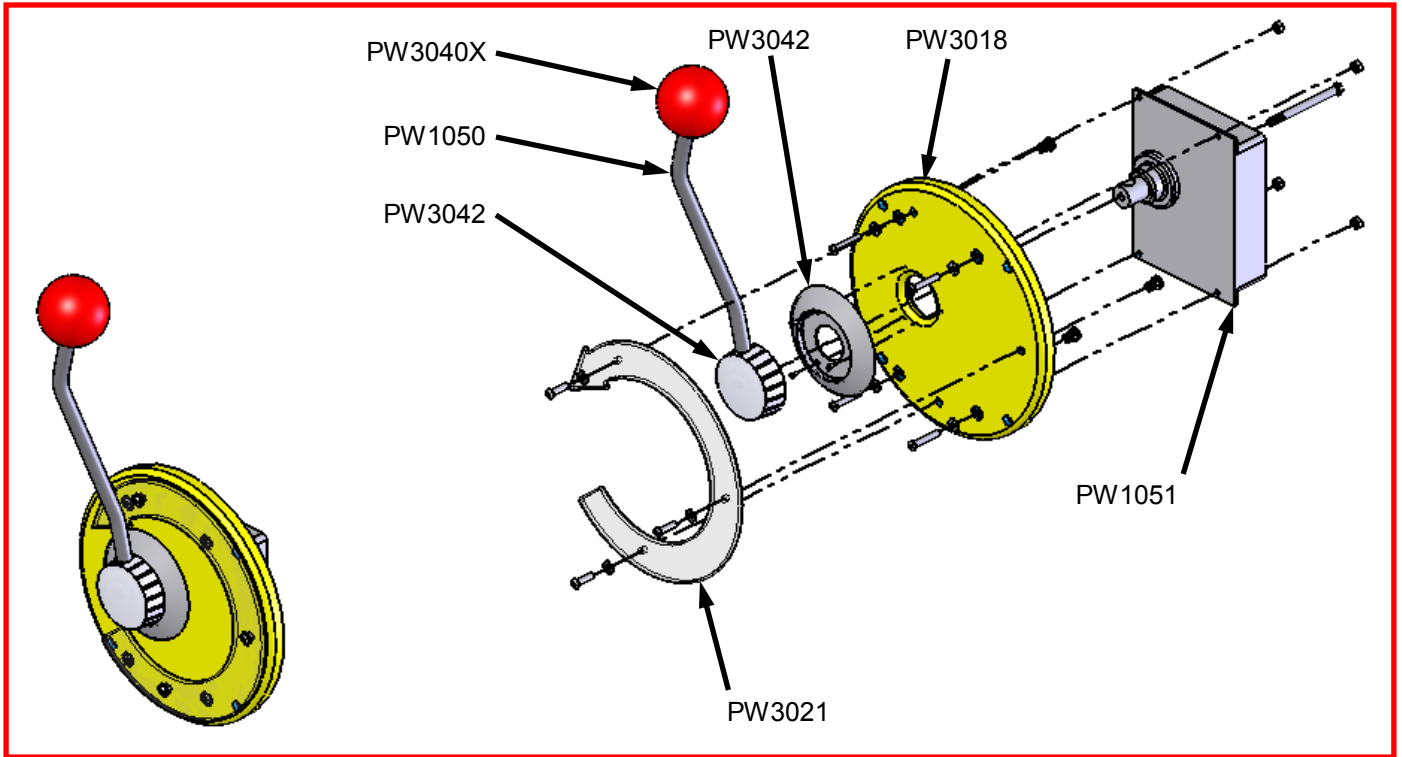

Lever Arm Assembly

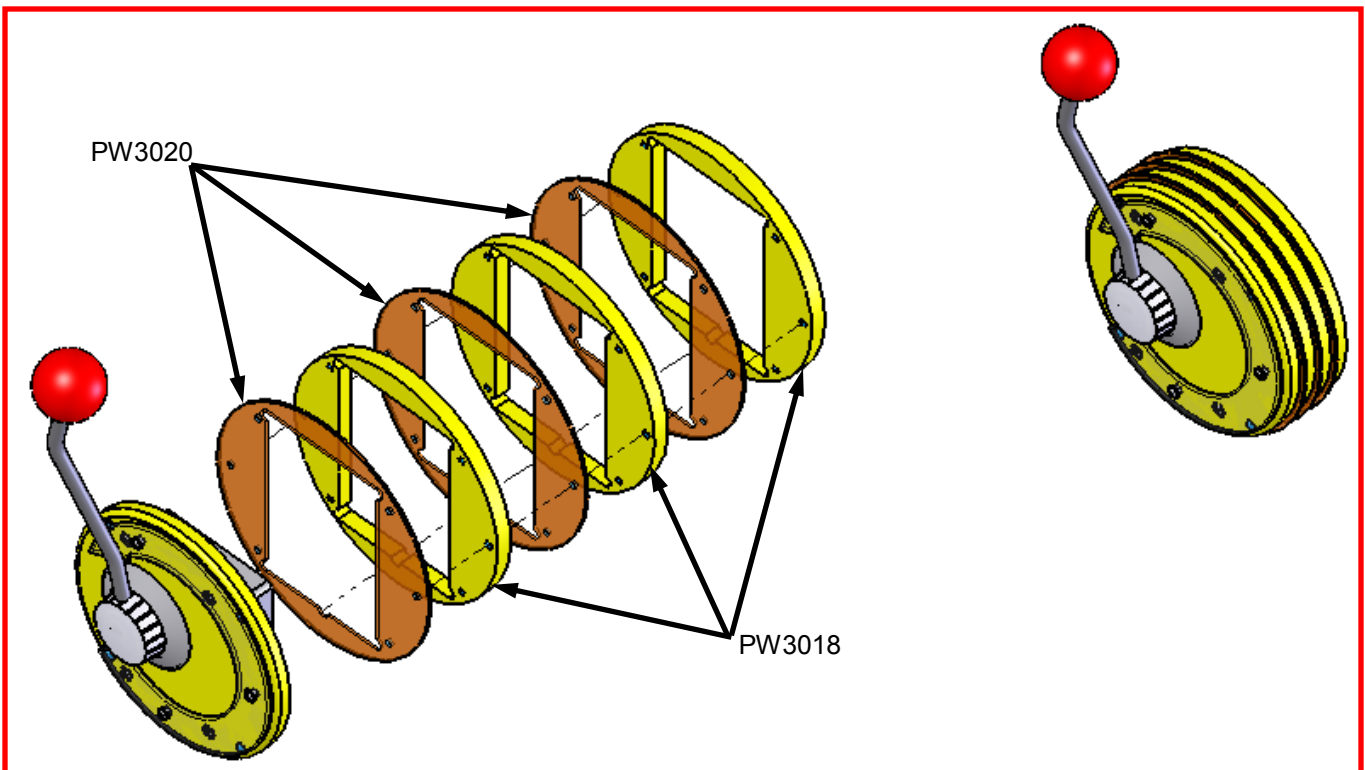

PW1051 Spring Part Break Down

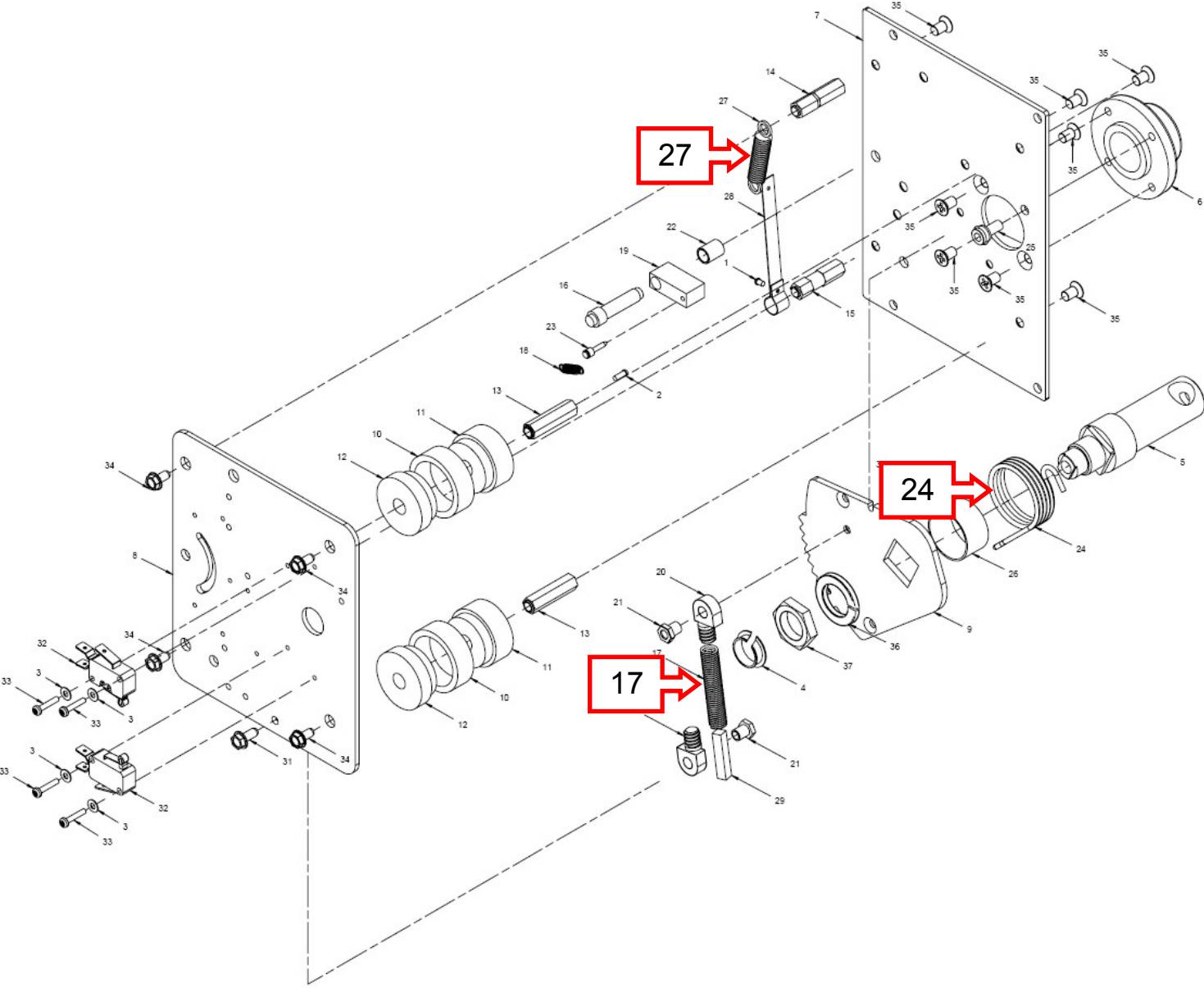

<i>ICE PART</i>	<i>Description</i>	<i>Location</i>
PW1052	Spring Stop	(Part 27 above)
PW1053	Spring Torsion	(Part 24 above)
PW1054	Spring Main	(Part 17 above)

MAINTENANCE / REPAIR

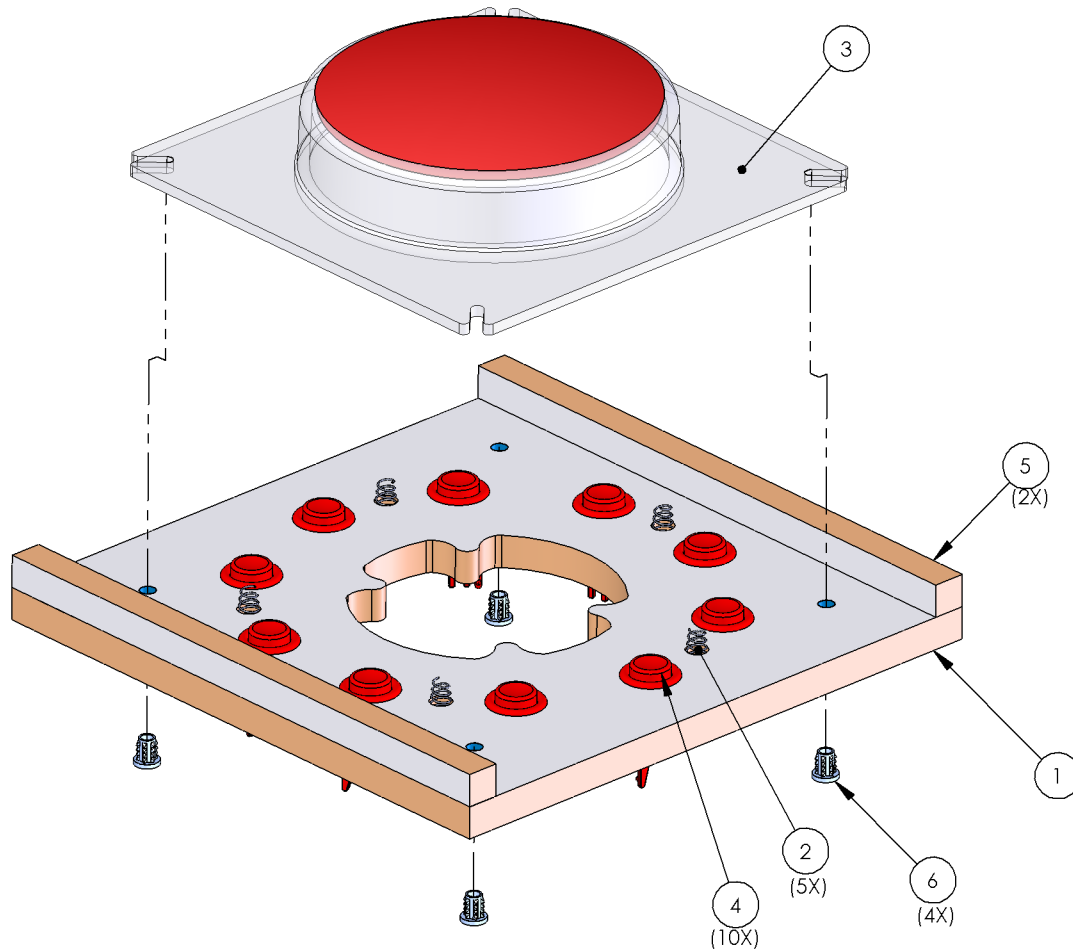

ITEM NO.	PART NO.	DESCRIPTION	QTY.
1	PW3083	BUTTON SUPPORT PANEL	1
2	CG1066	.700 X .3125 SPRING	5
3	BW3003	8" PUSH BUTTON	1
4	EV2005	RED SOLID BUTTON	10
5	PW3084	PUSH BUTTON CLEAT	2
6	PC60631	1/4-20 CABINET INSERT	4

PW7007 PLACEMENT INSTRUCTIONS

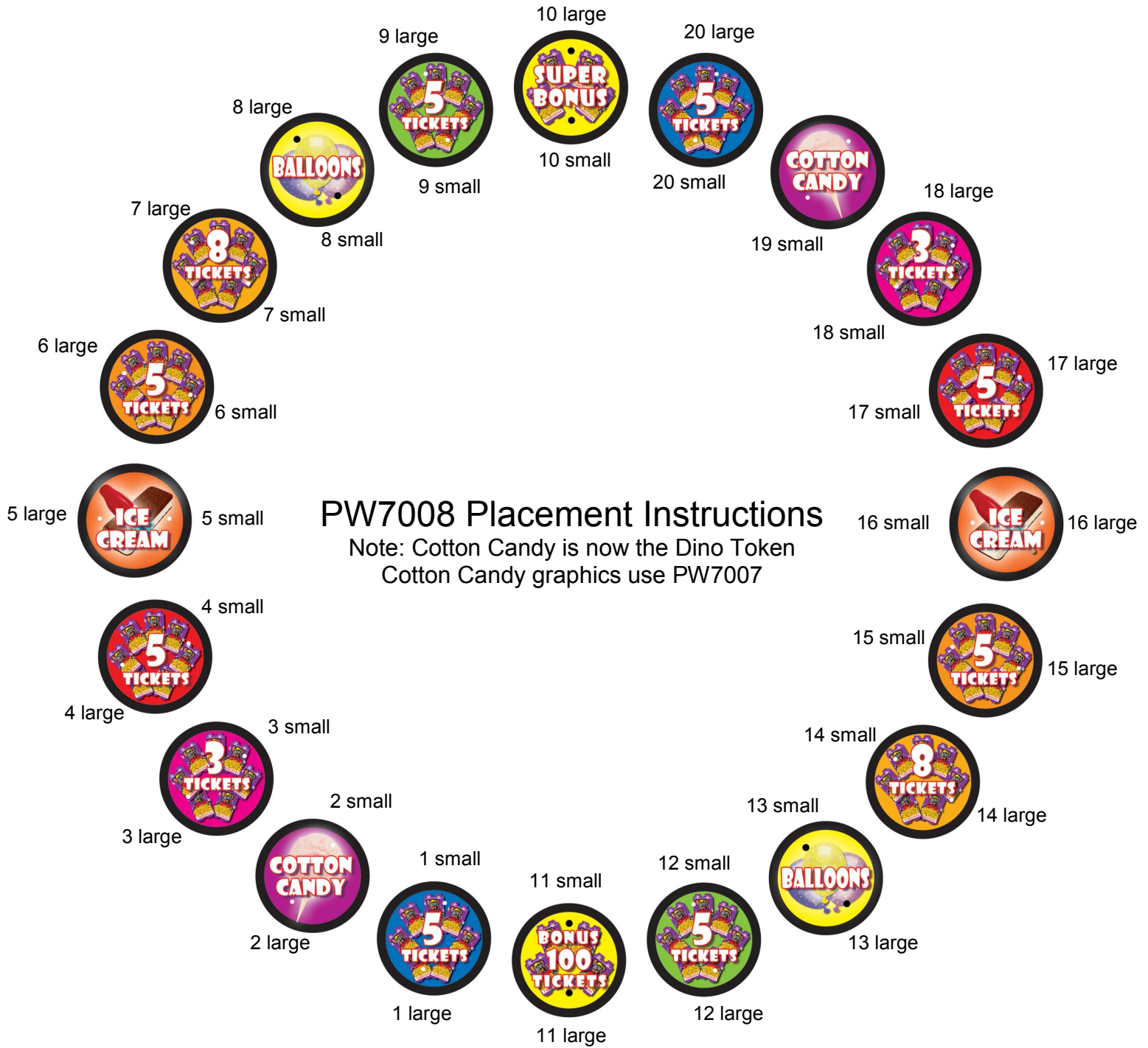

This page is to be used for placement of the Prize “Pucks” and for use in troubleshooting using the System Schematic found on the following page. If you have the hopper option, you will have Dino tokens instead of balloons.

PARTS LISTINGS

Misc. Parts

PW3009	Kick Plate
PW3016	Printer Face
PW3017	DBV Cover
PW3022	Prize Graphic Panel
PW1016	Hopper Frame
PW1015x	Coin chute assembly

Electrical Parts

PW2130X	Assembly (Ceramic Bulb Socket)
HH5005D	Ticket Dispenser
8690	Bulb Compact Fluorescent
DA2001x	PCBA (Power Supply)
DA2002x	Assy. (Transformer)
DD2007x	Assy. (Power Module)
PP250x	Light Socket
PW5000	Coupon Printer
PW5001	Power Supply
MZ2006	Zamperella Light
PW2034X	PCB Mainboard
FG2007	6 x 9 Speakers
EV2005	2" Button Red Solid
BW3003	8" Push Button
CR07113D	Hopper
PW1052	Spring Stop
PW1053	Spring Torsion
PW1054	Spring Main

Graphics and Decals

PW7001	Decal - Center Wheel
PW7002	Decal - Front Panel
PW7003	Decal - Middle Chuck E Graphic
PW7005A	Decal - Prize Wheel Top Half
PW7005B	Decal - Prize Wheel Bottom Half
PW7007	Decal - Prize Graphic Package Cotton Candy
PW7008	Decal - Prize Graphic Package Dino Token
PW7012	Decal - Control
PW7013	Decal - Control Panel Pull Lever

Warranty

I.C.E warrants all components in the **Big Win Super Spin™** game to be free of defects in materials and workmanship for a period of ninety days from the date of purchase.

This warranty does not cover items damaged due to normal wear and tear, subjected to abuse, improperly assembled by the end user, modified, repaired, or operated in a fashion other than that described in the service manual.

If your **Big Win Super Spin™** game fails to conform to the above-mentioned warranty, I.C.E.'s sole responsibility shall be at its option to repair or replace any defective component with a new or remanufactured component of equal to or greater O.E.M. specification.

I.C.E. will assume no liability whatsoever, for costs associated with labor to replace defective parts, or travel time associated therein.

I.C.E.'s obligation will be to ship free of charge, replacement parts by domestic U.P.S. Ground, U.S. mail, or other comparable shipping means. Any express mail or overnight shipping expense is at the cost of the purchaser.

Products will be covered under warranty only when:

- The serial number of the game with the defective parts is given. A tech number has been issued by an I.C.E. technical representative.
- The serial number of the defective part, if applicable, is given.
- Defective parts are returned to I.C.E., shipping pre-paid, in a timely fashion, if requested by I.C.E.
- A copy of the sales receipt is available as proof of purchase upon request of I.C.E.

I.C.E. distributors are independent, privately owned and operated. In their judgment, they may sell parts or accessories other than those manufactured by I.C.E. We cannot be responsible for the quality, suitability, or safety of any non-I.C.E. part, or any modification, including labor, which is performed by such a distributor.



WARRANTY

ICE Inc warrants that all of its products will be free from defects in material and workmanship.

When placing a warranty request, please be prepared to provide the following information:

- Serial Number of Game or Bill of Sale
- Machine Type
- A Detailed Description of the Equipment Fault Symptoms

ICE product, including Cromptons, Sam's Billiards, Uniana and Bell Fruit is warranted as follows:

- 180 days on the Main PCB and Computers
- 180 days on Motors
- 180 days on Monitors
- 90 days on all other components (i.e. DBV's, Ticket Dispensers, sensors, etc)

ICE Inc shall not be obligated to furnish a warranty request under the following conditions:

- Equipment has been subjected to unwarranted stress through abuse or neglect
- Equipment has been damaged as a result of arbitrary repair/modification attempts
- Equipment that has failed through normal wear and tear

ICE Inc will assume no liability whatsoever for costs associated with labor to replace defective parts or travel time associated therein.

All defective warranty covered components will be replaced with new or factory refurbished components equal to OEM specifications. ICE Inc will cover all domestic UPS ground, or comparable shipping means, freight costs during the warranty period. Expedited shipments are available for an additional charge.

Defective parts are returned to ICE Inc, at the customer's expense, in a timely fashion.

ICE distributors are independent, privately owned and operated. In their judgment, they may sell parts and/or accessories other than those manufactured by ICE Inc. We cannot be responsible for the quality, suitability or safety of any non-ICE part, modification (including labor) that is performed by such a distributor.

I.C.E. Parts/Service Dept.
Innovative Concepts in Entertainment
10123 Main St.
Clarence, NY 14031
Phone #: (716) - 759 - 0360
Fax #: (716) - 759 - 0884